

GROUND FRAME™

Installation Instructions Container



OVERVIEW

The Ground Frame Foundation System provides a solid, stable, and efficient foundation that captures and preserves the supporting strength and natural functions of the Earth's soil and provides a connection to the structure above.

IMPORTANT NOTE:

- Ensure all permits have been obtained.
- Check for buried utilities, mark on site as per local building codes.
- Have all required tools and equipment outlined on page 2.
- Wear proper personal protective equipment (PPE).

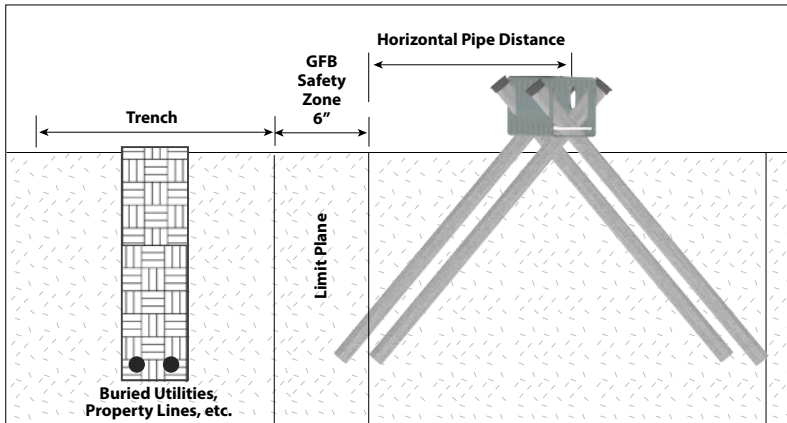

Horizontal Pipe Distance

Measured from horizontal center of anchor bolt to vertical pipe end limit

| Pipe Length (Inches) | Horizontal Pipe Distance (inches) |
|-------------------------|--|
| | Pipe at 90 degrees Perpendicular to limit plane |
| 50 | 29 |
| 63 | 38 |
| 84 | 51 |

GROUND FRAME CONTAINER OVERVIEW

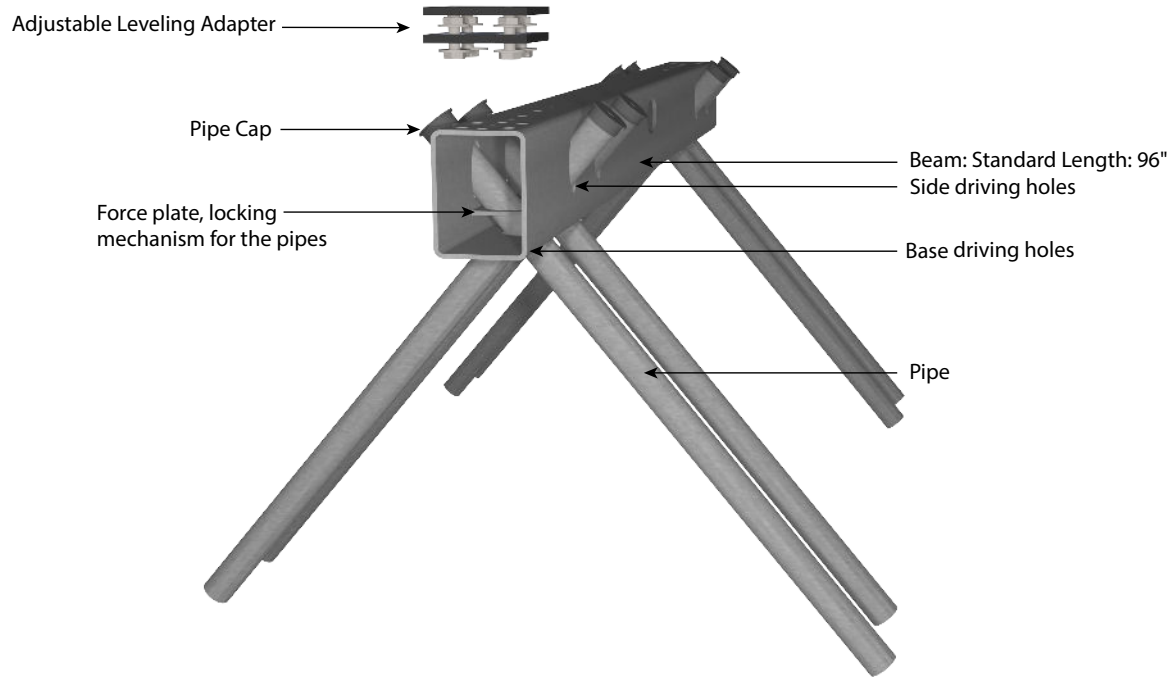

GROUND FRAME SMART PART NUMBERS

Simplify field inventory checks using our smart part numbers.

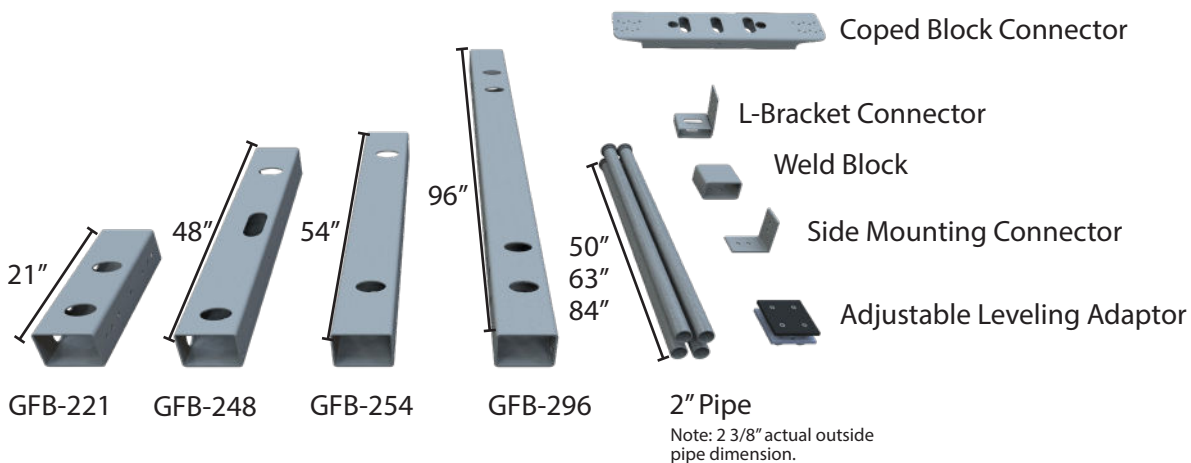
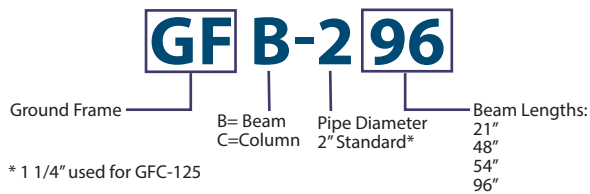

SUGGESTED CREW AND TOOLS



Three-person crew for beam installation, two-person for column



Site transit level



Electric driving hammer (60 lb or greater) with driving bit



Sledgehammer or post driver



Small level with magnetic edge



Torque wrench, Socket, Ratcheting wrench



Drill and impact driver



Square-edge shovel required for column installation



Steel Stake (36" length)
(Use for batter boards and for plumbing beams)



2 Pipe Wrenches
(Use heavy duty pipe wrenches that will go over the outside diameter of the pipe)

Driving log

Note: Download template at groundframes.com

BEFORE YOU BEGIN

Check Pipes for Proper Slide

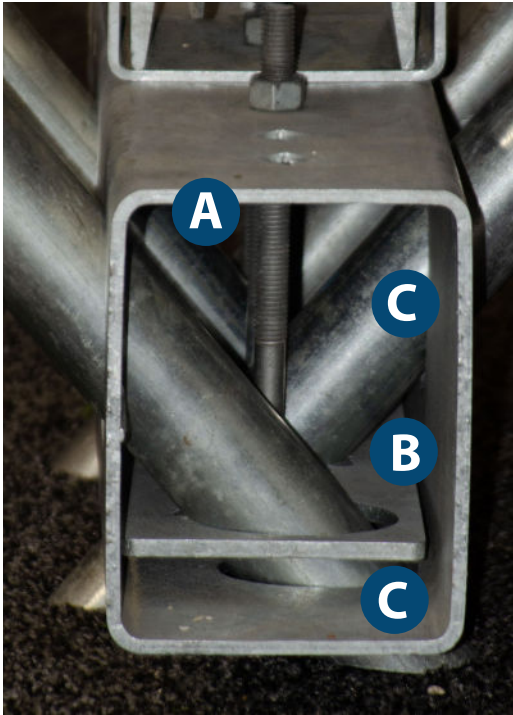

- A** Anchor bolt
- B** Force plate
- C** Driving holes - side and base

The anchor bolt and force plate are factory set for proper pipe slide, but may have altered during shipping and handling.

Pipes should easily slide through holes. If pipes do not easily slide, loosen locking bolt. **Do NOT force the pipes through the beam/column holes.**

If the bolt is fully loosened and the pipes do not easily slide, contact Ground Frame customer service.

| Do | Don't |
|---|-------------------------------------|
| Follow the instructions in this guide. | Proceed without reading this guide. |
| Use only specified hardware. | Substitute hardware |
| Review troubleshooting tips to safely remove pipes or adjust pipes. | Force pipes past obstructions |

SITE PREPARATION



1. Using the dimensioned layout as a guide, establish the container border with a string line. Ensure alignment with string line.

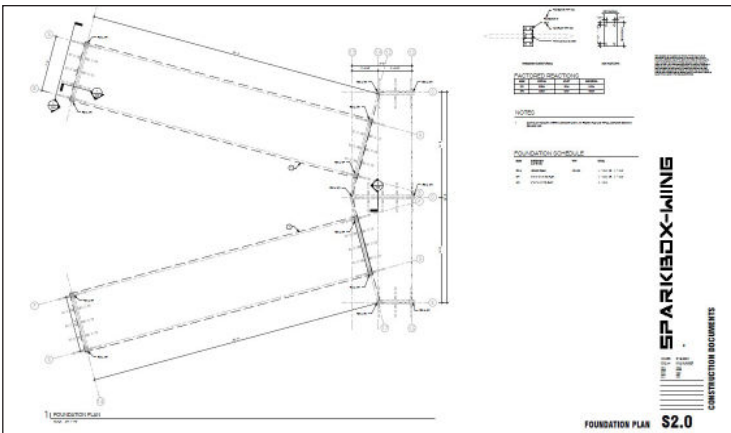

2. Clear and level site as per approved plans. Ensure proper site drainage and desired floor height.

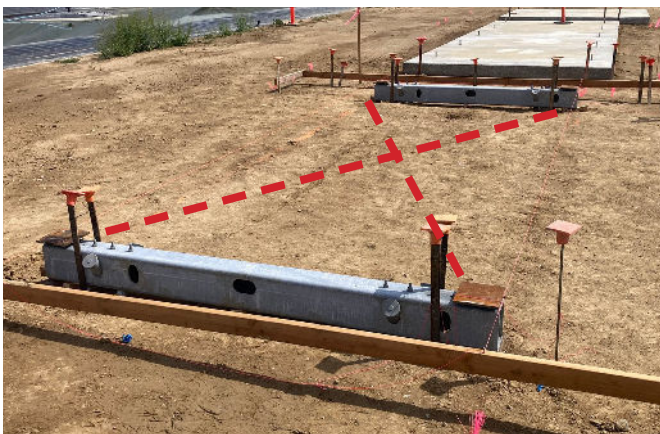

3. Measure diagonally to ensure the border is squared.



4. Find the elevation of a "Master Corner" (the highest corner).

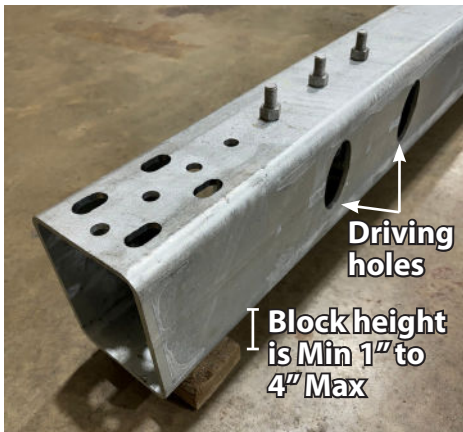

5. Block and shim the end of the steel beams to the same level as the master corner or within leveling plate adjustability range. Minimum block height is 1" and maximum height is 4" for frost heave. Ensure driving holes remain open and are not blocked by shims.



6. Verify all outer dimension according to the dimensioned layout. Ensure steel beams are plumb, level, and square to the overall layout.



Best practice is to cradle the beam with 4 stakes to ensure it stays on layout when driving pipes. Continue to page 7 for pipe installation.

PIPE INSTALLATION

Ground Frame strongly recommends using a minimum two-person crew for pipe driving.

Ground Frame pipes are not refusal driving systems. All pipes must be driven to their full length to provide specified bearing, uplift and lateral capacities.



7. Upon leveling completion, gather and stage Ground Frame pipes.

- A** Anchor bolt
- B** Force plate
- C** Driving holes - side and base

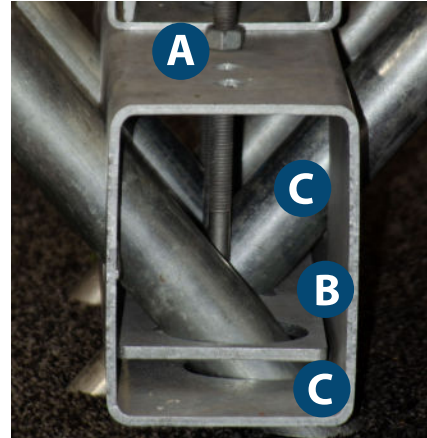

8. Ensure the pipe can easily slide through the side driving hole.

Important Note: If pipe does not easily slide, loosen the nut (on top of beam), lowering the force plate.



9. To ensure the pipe maintains the proper angle, hold it against the upper ellipse of the side driving hole.



10. Using a sledgehammer, drive the pipe in a few inches, to maintain the proper angle.

TROUBLESHOOTING

SHALLOW OBSTRUCTION: ~1/3 Pipe Length in the Ground

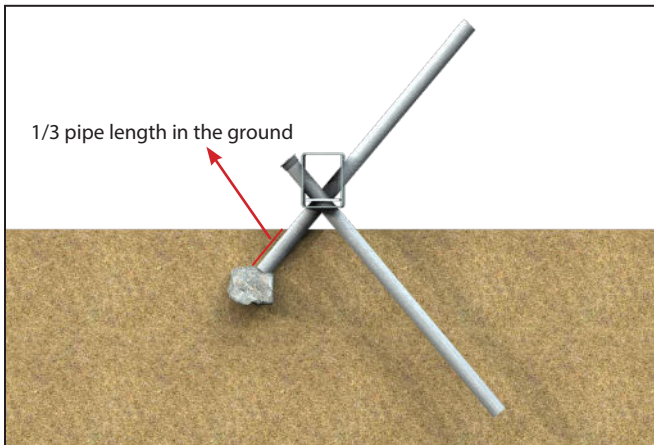

1. Remove pipe.

Tip: Simultaneously spin and pry pipe, using two pipe wrenches with two people.

2. Remove obstruction and recompact soil in 6" lifts.

3. Redrive pipe.

DEEP OBSTRUCTION: 2/3 Pipe Length in the Ground

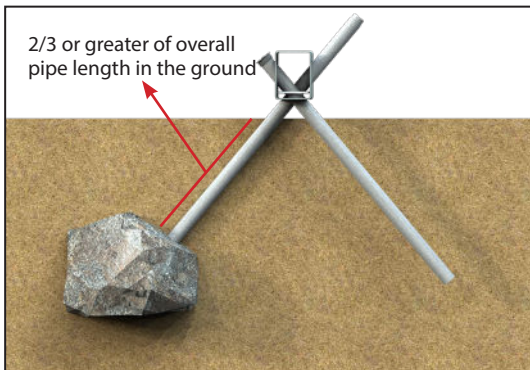

1. Using a sledgehammer, strike the pipe, 3-5 blows, to ensure pipe refusal.

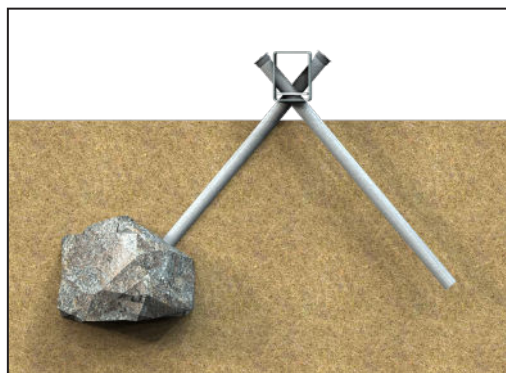
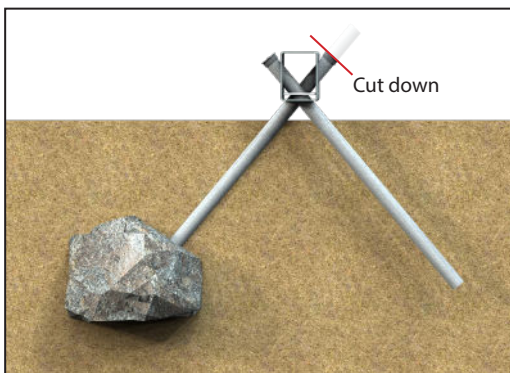

2. Cut the remaining portion of the pipe, above the Ground Frame beam, and cap.

Important Note: Indicate the length of the pipe that was cut off in the driving log.