

GROUND FRAME™

Installation Instructions

Beam (GFB-200)



OVERVIEW

The Ground Frame Foundation System provides a solid, stable, and efficient foundation that captures and preserves the supporting strength and natural functions of the Earth's soil and provides a connection to the structure above.

IMPORTANT NOTE:

- Ensure all permits have been obtained.
- Check for buried utilities, mark on site as per local building codes.
- Have all suggested tools and equipment outlined on page 2.
- Wear proper personal protective equipment (PPE).

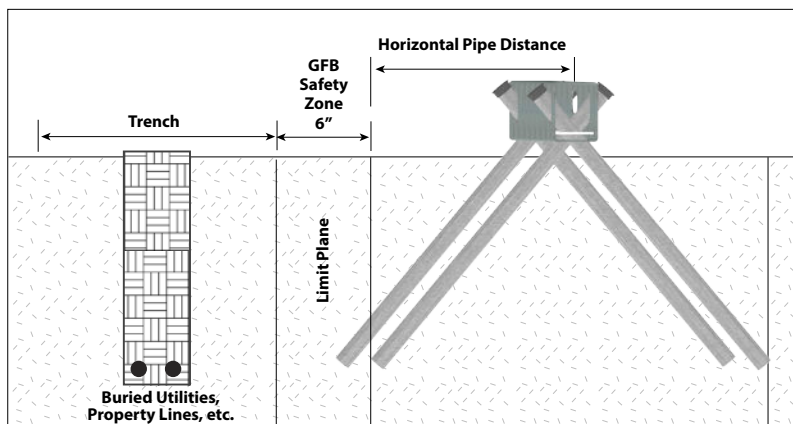

Horizontal Pipe Distance

Measured from horizontal center of anchor bolt to vertical pipe end limit

Pipe Length (Inches)	Horizontal Pipe Distance (inches)
	Pipe at 90 degrees Perpendicular to limit plane
50	29
63	38
84	51

GROUND FRAME BEAM OVERVIEW

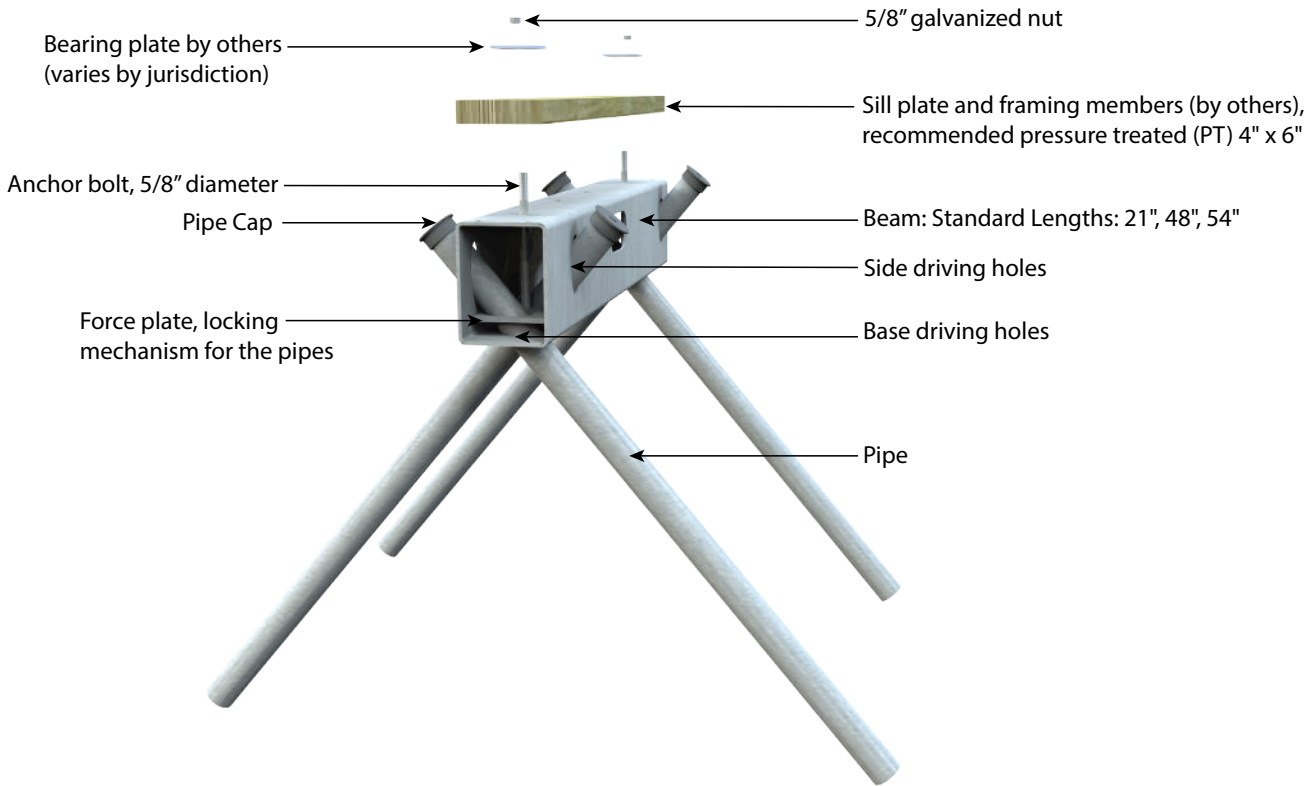

GROUND FRAME SMART PART NUMBERS

Simplify field inventory checks using our smart part numbers.

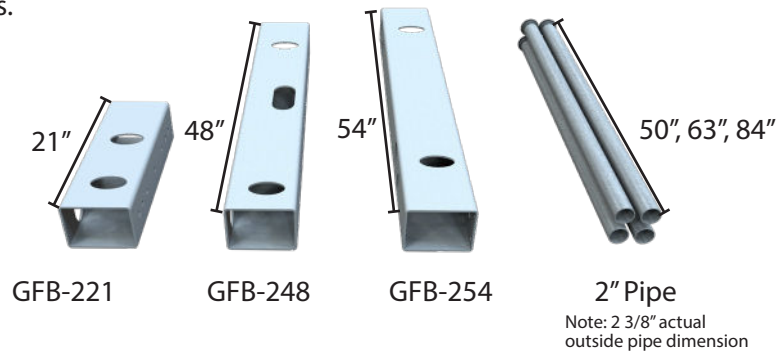
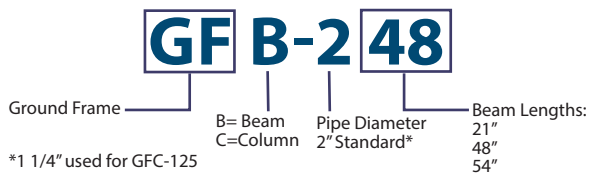

BEAM CONFIGURATION DO'S AND DONT'S

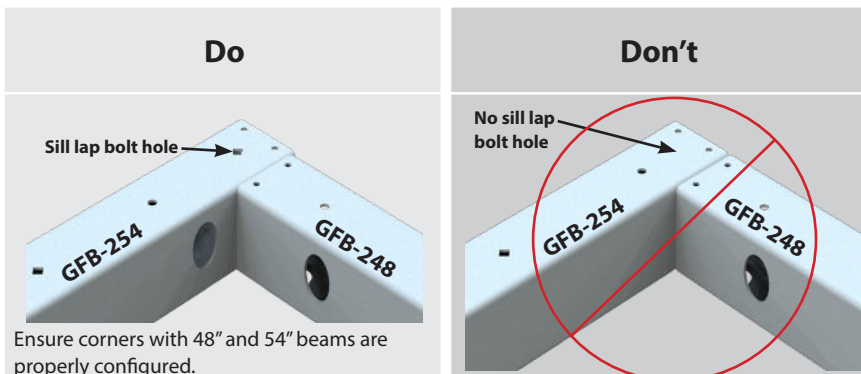

SUGGESTED CREW AND TOOLS



Three-person crew for beam installation, two-person for column



Site transit level



Electric driving hammer (60 lb or greater) with driving bit



Sledgehammer or post driver



Small level with magnetic edge



Torque wrench, Socket, Ratcheting wrench



Drill and impact driver



Square-edge shovel required for column installation



Steel Stake (36" length)
(Use for batter boards and for plumbing beams)



2 Pipe Wrenches
(Use heavy duty pipe wrenches that will go over the outside diameter of the pipe)

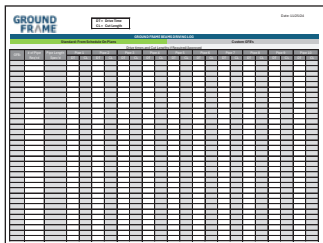

Driving log

Note: Download template at groundframes.com

Do	Don't
Follow the instructions in this guide.	Proceed without reading this guide.
Use only specified hardware.	Substitute hardware
Review troubleshooting tips to safely remove pipes or adjust pipes.	Force pipes past obstructions

BEFORE YOU BEGIN

Check Pipes for Proper Slide

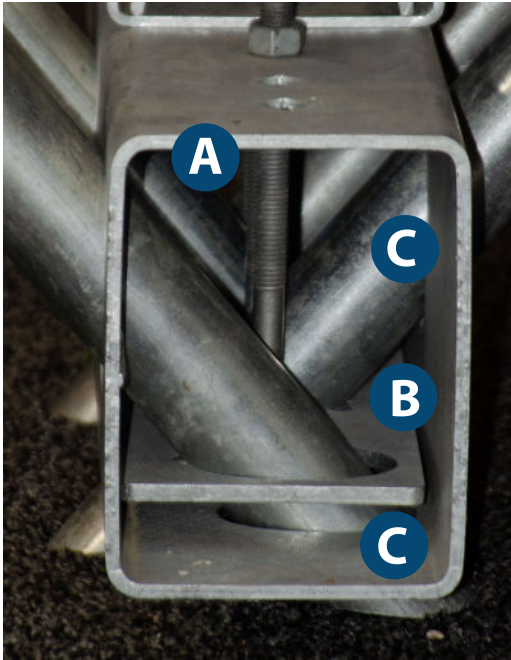

- A** Anchor bolt
- B** Force plate
- C** Driving holes - side and base

The anchor bolt and force plate are factory set for proper pipe slide, but may have altered during shipping and handling.

Pipes should easily slide through holes. If pipes do not easily slide, loosen locking bolt. **Do NOT force the pipes through the beam/column holes.**

If the bolt is fully loosened and the pipes do not easily slide, contact Ground Frame customer service.

SITE PREPARATION

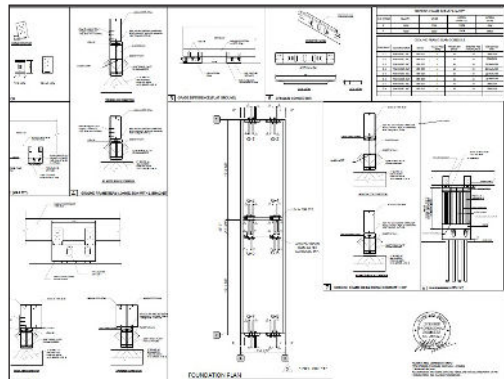

1. Clear and level site as per approved plans. Ensure proper site drainage and desired floor height.

2. Using the dimensioned layout as a guide, establish the building border with a string line. **For sloped sites, see page 11.**



3. Measure diagonally to ensure the border is squared.



4. Find the elevation of a "Master Corner" (the highest corner).

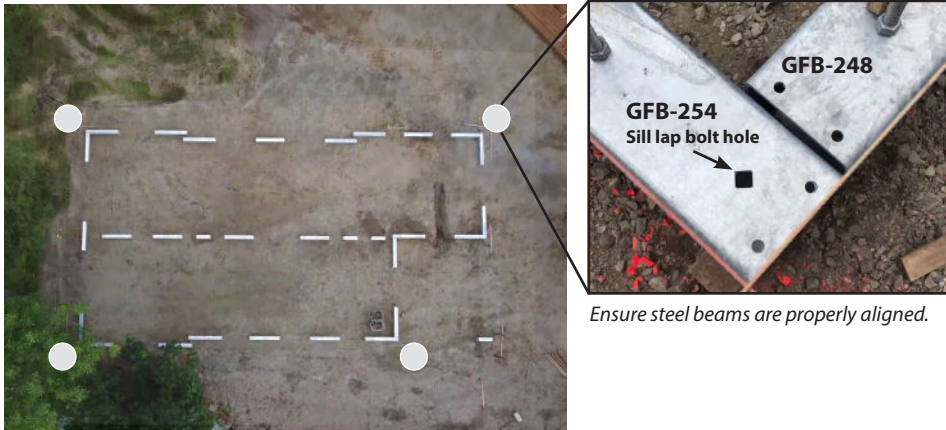

5. Using the dimensioned layout, roughly stage the Ground Frame steel beams. It is best practice to start in the corners.



6. Block and shim the end of steel beams to the same level as the master corner. Minimum block height is 1" for frost heave.



7. Maximum block height is 4".



8. Ensure driving holes remain open and are not blocked by shims.



9. Ensure steel beams are properly aligned as per the dimensioned layout.



10. Verify all outer dimensions according to the dimensioned layout. Ensure steel beams are plumb, level, and square to the overall layout. **For sloped sites, see page 11.**



SECURE AND BRACE SILL AND FRAMING BEAMS



11. Pre-drill the recommended 4" x 6" sill plates, using a 3/4" bit, where the anchor bolts are located. It is best practice to start in the corners. Install header beam to the sill plate, prior to placing on steel beams.



12. Place the pre-drilled sill plate and header beam over the anchor bolts.



13. Add the specified bearing plate, finger tighten the bolts.



14. When two Ground Frame steel beams meet at a corner, ensure that the sill plates overlap on top, in a manner that is opposite to the steel beams.



15. Continue installing the sill plates and headers. Ensure end cuts are treated.



16. Construct the cripple walls on top of the sill plates per the plan. Frame cripple walls off the sill plates to specified dimensions.



17. Double check your elevations and make any necessary adjustments.

PIPE INSTALLATION

Ground Frame strongly recommends using a minimum two-person crew for pipe driving.

Ground Frame pipes are not refusal driving systems. All pipes must be driven to their full length to provide specified bearing, uplift and lateral capacities.

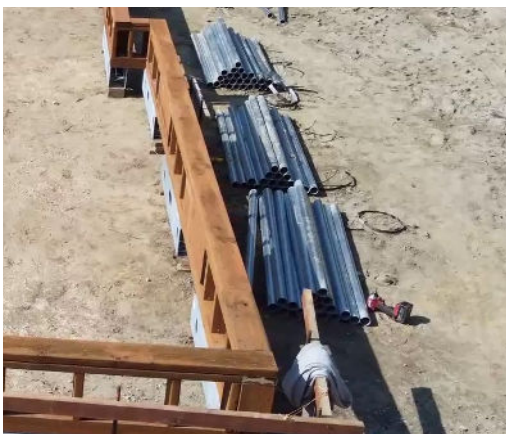

18. Upon framing completion, gather and stage Ground Frame pipes.

- A** Anchor bolt
- B** Force plate
- C** Driving holes - side and base

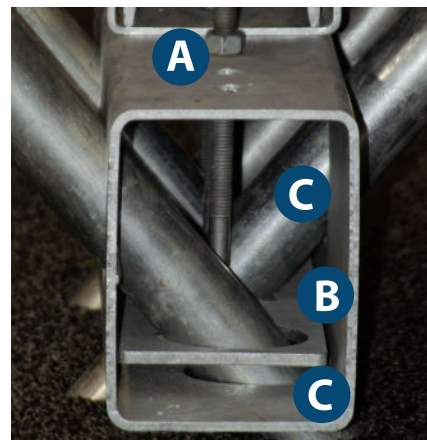

19. Ensure the pipe can easily slide through the side driving hole.

Important Note: If pipe does not easily slide, loosen the nut (on top of beam), lowering the force plate.



26. When pipe hits an obstruction, follow the troubleshooting steps found on page 10.



27. Install pipe caps on top of each pipe.



28. Torque all bolts to 55 ft. lbs. Remove leveling blocks (installed in step 6-8) after torquing.

TROUBLESHOOTING

SHALLOW OBSTRUCTION: ~1/3 Pipe Length in the Ground

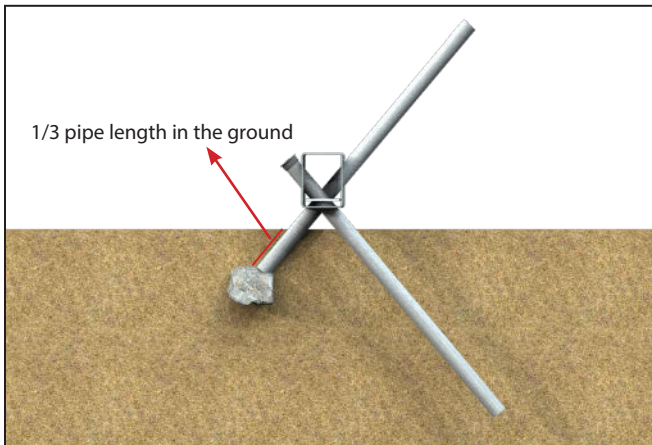

1. Remove pipe.

Tip: Simultaneously spin and pry pipe, using two pipe wrenches with two people.

2. Remove obstruction and recompact soil in 6" lifts.

3. Redrive pipe.

DEEP OBSTRUCTION: 2/3 Pipe Length in the Ground

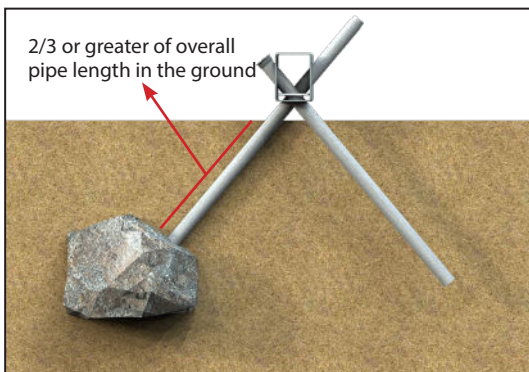

1. Using a sledgehammer, strike the pipe, 3-5 blows, to ensure pipe refusal.

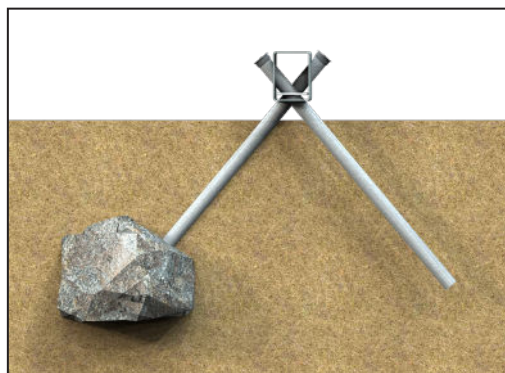
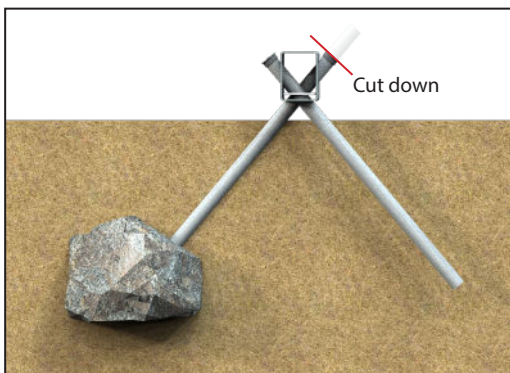

2. Cut the remaining portion of the pipe, above the Ground Frame beam, and cap.

Important Note: Indicate the length of the pipe that was cut off in the driving log.

SLOPED SITE ADDENDUM



Sloped lot with Ground Frame Beams

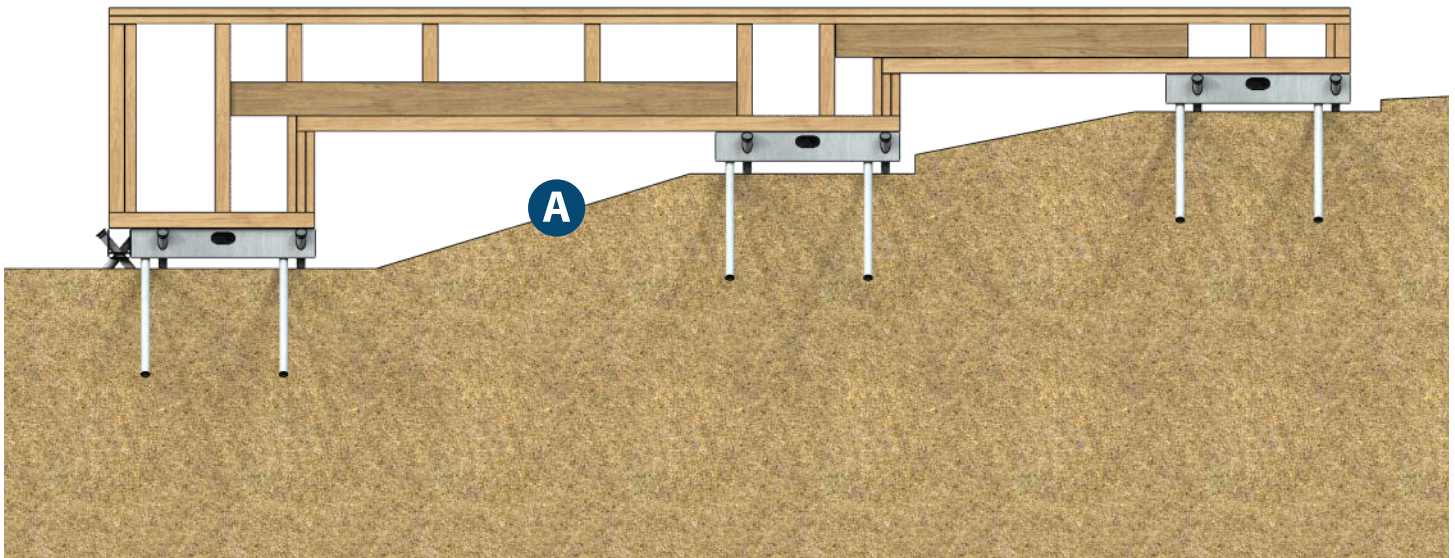

A Maximum recommended slope 3:1.